

Universal Panels & Accessories

Erection Procedures



INTRODUCTION

Use common sense when working with Scaffold Your Safety is our #1 Concern

Universal Scaffolds are designed with your safety in mind every step of the way. They are the products of input from you, the actual end user, and Universal Manufacturing Corp., a leader in safe access equipment for over 70 years. It is in the best interest of the Construction Industry as a whole to maintain SAFE and therefore, productive job sites.

This Manual was designed to improve your erection time and performance of your worksite by providing information on general erection and maintenance guidelines. Consult your scaffold supplier or Universal if you are unsure of anything or if you require additional information. Universal Manufacturing Corp. offers Engineering Services to their customers, which includes load information, AutoCAD Drawings, special product design and information on all OSHA requirements.

CONTENTS

Introduction	1
Definitions of Competent & Qualified Person	2
General Notes	3
Universal Stationary Scaffold	4, 5
Typical Rolling Tower	6
High Rolling Tower	7
Putlogs & Proper Installation	8, 9
Scaffold Access Unit	10
Scaffold Access-Alternate Construction	11
Typical Tank Layout	12
Universal Scaffold “Ezebilt”	13
Universal Scaffold “Unibilt”	14
Scaffold Inspection Procedures	15
Scaffold Industry Association (Code of Safe Practices)	16, 17

A QUALIFIED PERSON

Means one who, by possession of a recognized degree, certificate, or professional standing, or who by extensive knowledge, training, and experience, has successfully demonstrated his/her ability to solve or resolve problems related to the subject matter, the work, or the project.

COMPETENT PERSON

Must have had specific training in and be knowledgeable about the structural integrity of scaffolds and the degree of maintenance needed to maintain them. The competent person must also be able to evaluate the effects of occurrences such as a dropped load, or a truck backing into a support leg that could damage a scaffold. In addition, the competent person must be knowledgeable about the requirements of this standard. A competent person must have training or knowledge in these areas in order to identify and correct hazards encountered in scaffold work.

GENERAL NOTES

- 1) Please remember it is DANGEROUS AND ILLEGAL to erect any Scaffold System without proper Guardrail, Midrail and Toeboard Components.
- 2) Mixing components of other Scaffold such as Frames, Braces, Guardrail, etc. is considered improper use of Scaffold which creates a dangerous work site.
- 3) Since field conditions vary and are beyond the control of Universal Scaffolds, safe and proper erection and use of scaffolding is the sole responsibility of the user.
- 4) Metal tubular frame scaffold including all accessories such as Braces, Brackets, Putlogs, Adjustable Bases, Ladders, etc...are designed per Universal Manufacturing Corp. and OSHA requirements.
- 5) Periodic inspections shall be made on all welded frames and associated components. The manufacturer shall authorize any modifications or repairs.
- 6) No scaffold shall be erected, moved, dismantled or altered except under the supervision of competent personnel. (OSHA Code of Federal Regulations 1995 (a) (3) p. 356).
- 7) The footing or anchorage for Scaffolds shall be sound, rigid and capable of carrying the maximum intended load without settling or displacement. Unstable objects such as barrels, boxes, loose brick or concrete blocks shall not be used to support scaffolds or plank.
- 8) Clamp-on Ladders will extend at least 3 feet beyond the designated platform for safe access and egress.
- 9) All plank will be Scaffold Grade, or equivalent, as recognized by approved grading rules for the species of wood used. The maximum permissible spans for 2x10 inch or wider planks shall be as shown in the following:

	Full thickness Undressed Lumber		Nominal thickness Lumber
Working load (p.s.f.)	25	50	75
Permissible span (ft.)	10	8	6

(OSHA Code of Federal Regulations 1995, (a) (10) p. 357)

- 10) Sill plates (typically 2x10 scaffold plank) are required at the base of all stationary scaffolds to aid in uniform weight distribution and protect ground level surfaces.
- 11) OSHA requires a registered Professional Engineer to design all scaffolds over 125 feet in height.

Please remember it is DANGEROUS and ILLEGAL to erect any scaffold System without proper Guardrails, Midrails and toeboard. The system will conform to all government regulations now and in the future when properly erected with safety guidelines posted. Mixing components of other Scaffold such as Frames, Braces, Guardrail, etc. is considered improper use of scaffold which creates a dangerous work site. The OSHA requirements found in this manual will help you to provide a safe working condition for everybody.

UNIVERSAL STATIONARY SCAFFOLDING

Guardrail, entrance gates and toeboards shall be installed on all open sides and ends of platforms more than 10 feet above the ground or floor. Entrance gates should be erected so that they swing inward toward deck to open.

Guardrails should be 2" x 4" or the equivalent strength, installed no less than 38" or not more than 45" high, with a Midrail, when required, or 1" x 4" lumber or equivalent strength. All Guardrail shall be capable of supporting a 200 Lb. Load. Supports should be at intervals not to exceed 10 feet. Toeboards shall be a minimum of 4" in height above deck.

Scaffold planking shall extend over their end supports not less than 6" nor more than 18".

To prevent movement, the scaffold shall be secured to the building or structure at intervals not exceeding 30 feet horizontally nor 26 feet vertically.

Scaffold shall be secured to permanent structure through use of anchor bolts or other equivalent means.

Scaffold legs shall be set on Adjustable Bases or Plain Bases placed on mud sills or other foundations that are adequate to support the maximum intended load.

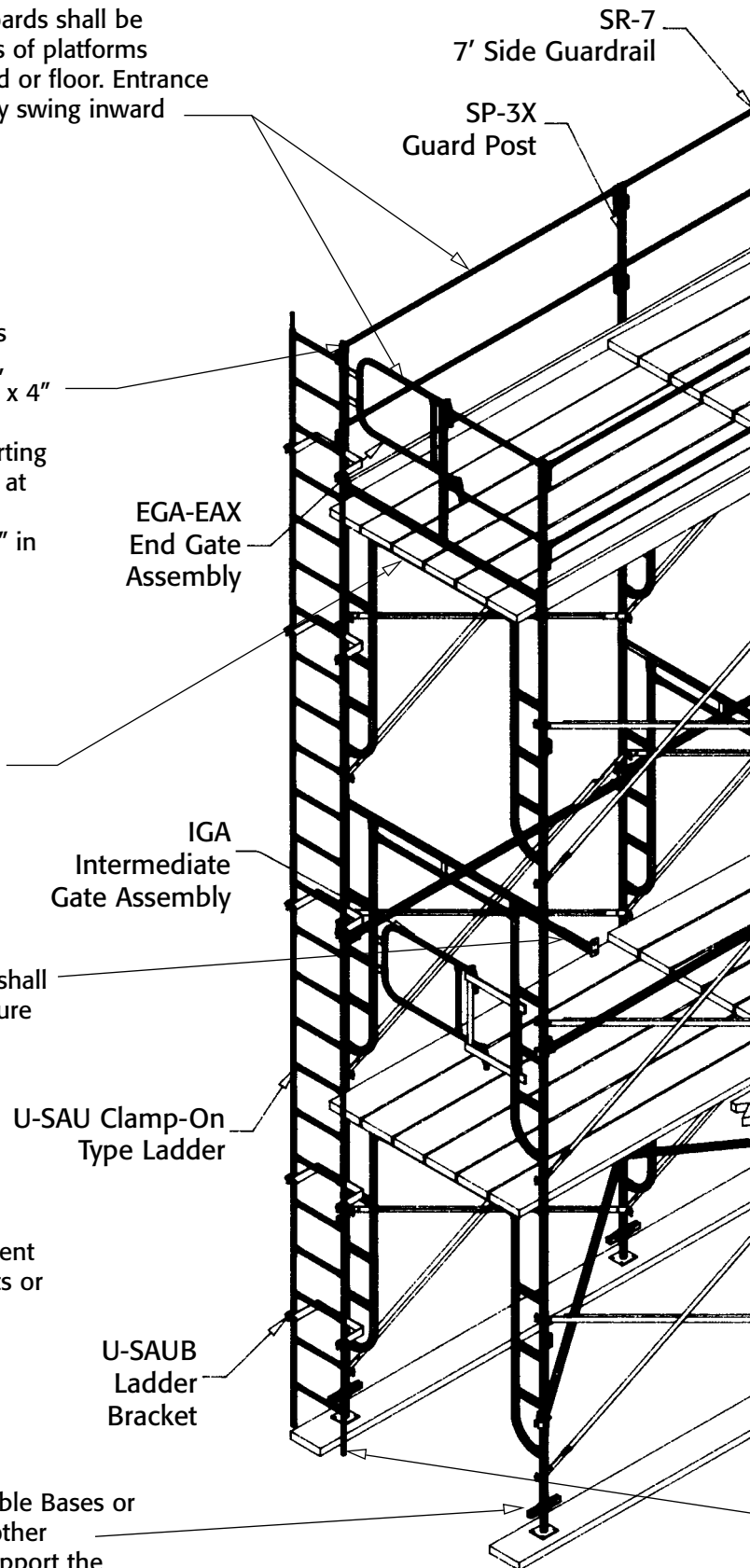

UNIVERSAL STATIONARY SCAFFOLDING

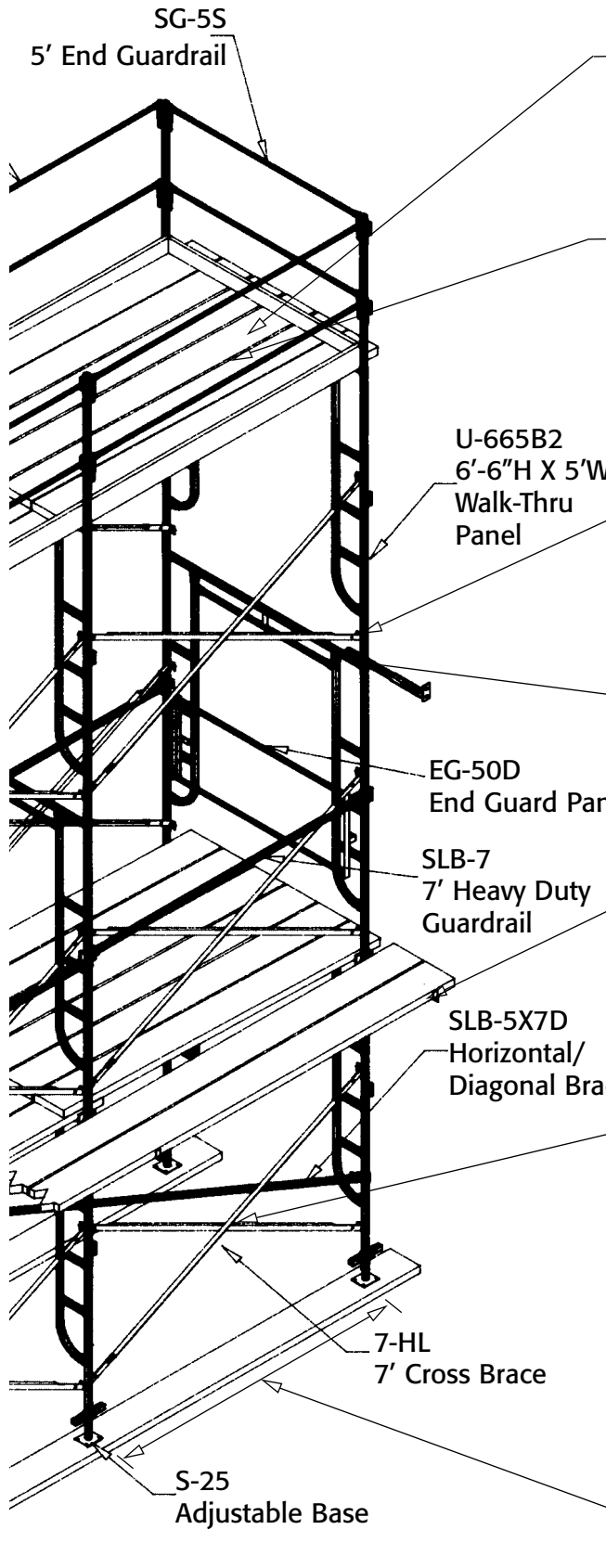

All planking or platforms shall be overlapped (a minimum of 12") or secured from movement. Platforms are to be fully decked between uprights.

All load carrying timber deck members shall have sufficient capacity to support the resulting loads imposed by the scaffold design criteria. If necessary, consult your scaffold supplier.

U-665B2
6'-6" H X 5' W
Walk-Thru
Panel

The Frames shall be placed one on top of the other with coupling or stacking pins to provide proper vertical alignment of the legs.

Frames shall be locked together vertically by pins or other equivalent suitable means.

EG-50D
End Guard Panel

SLB-7
7' Heavy Duty
Guardrail

When side brackets are used, the planking shall be overlapped as decking or cleated to secure properly. Guard posts and rail should be added when space between the brackets and sidewall exceeds 14".

SLB-5X7D
Horizontal/
Diagonal Brace

Scaffold shall be properly braced by cross bracing and diagonal bracing, for securing vertical members together laterally, and the cross brace shall be of such length as will automatically square and align vertical members so that the erected scaffold is always plumb, square and rigid. All brace connections shall be made secure.

7-HL
7' Cross Brace

S-25
Adjustable Base

Spacing of Frames shall be consistent with the loads imposed.

An Access Ladder or equivalent safe access shall be provided.

TYPICAL ROLLING TOWER

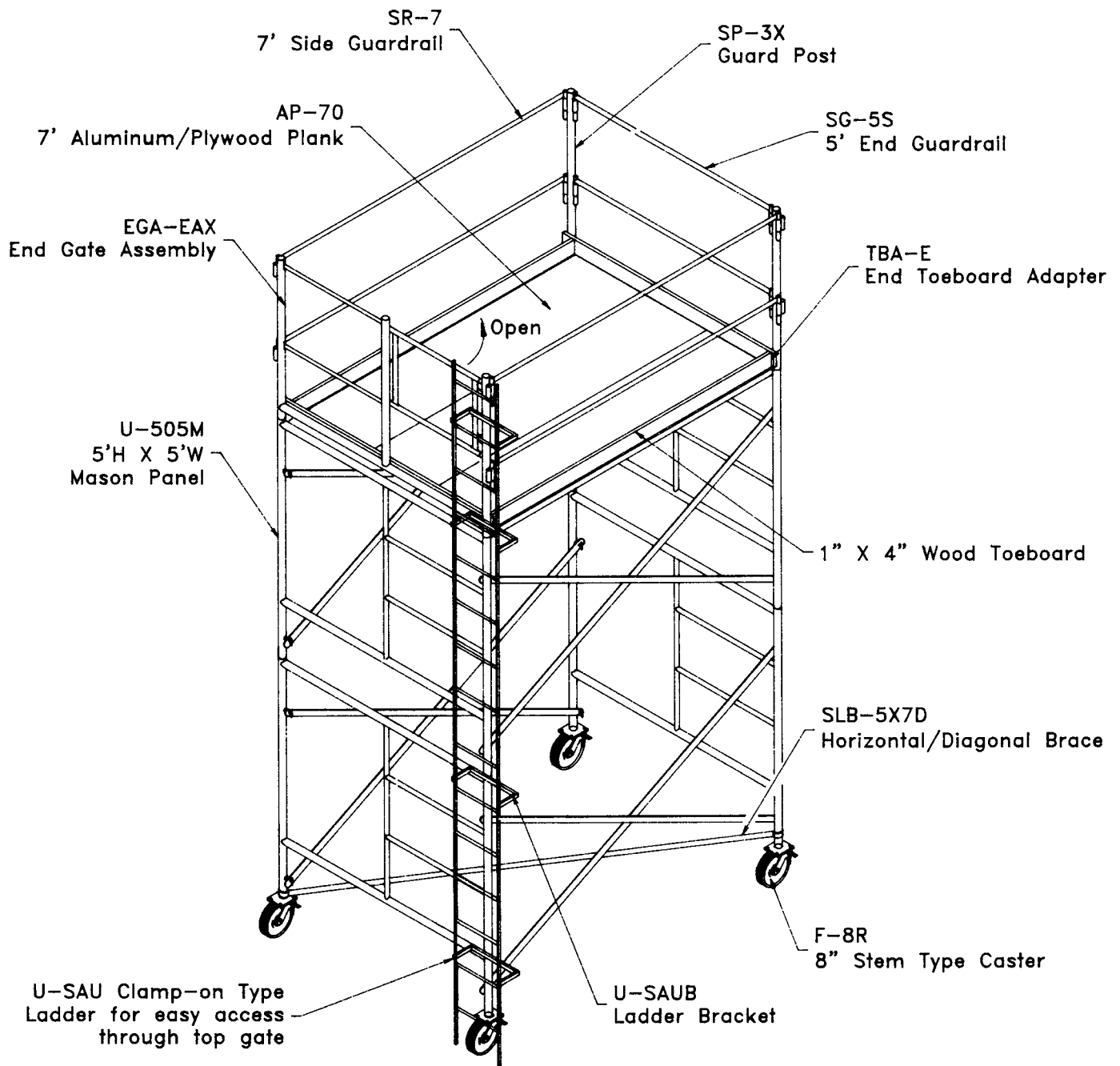

1. Details shown are for rolling towers not higher than four (4) times the smallest base dimension.
2. Casters must lock both rolling & "caster" motion.
3. All vertical connection points in Casters, Panels, Coupling Pins and Guard Posts must be secured to prevent possible uplift.
4. All work platforms, regardless of composition, must have cleats or otherwise secured to prevent any movement across Scaffold Panels.
5. Horizontal Diagonal Braces should be attached at the bottom, every 20' vertically and at the top.

High Rolling Scaffolding Tower

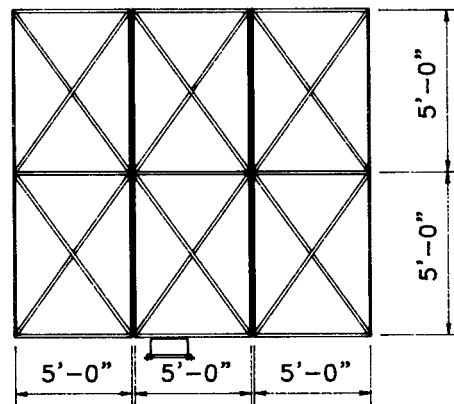

~PLAN~

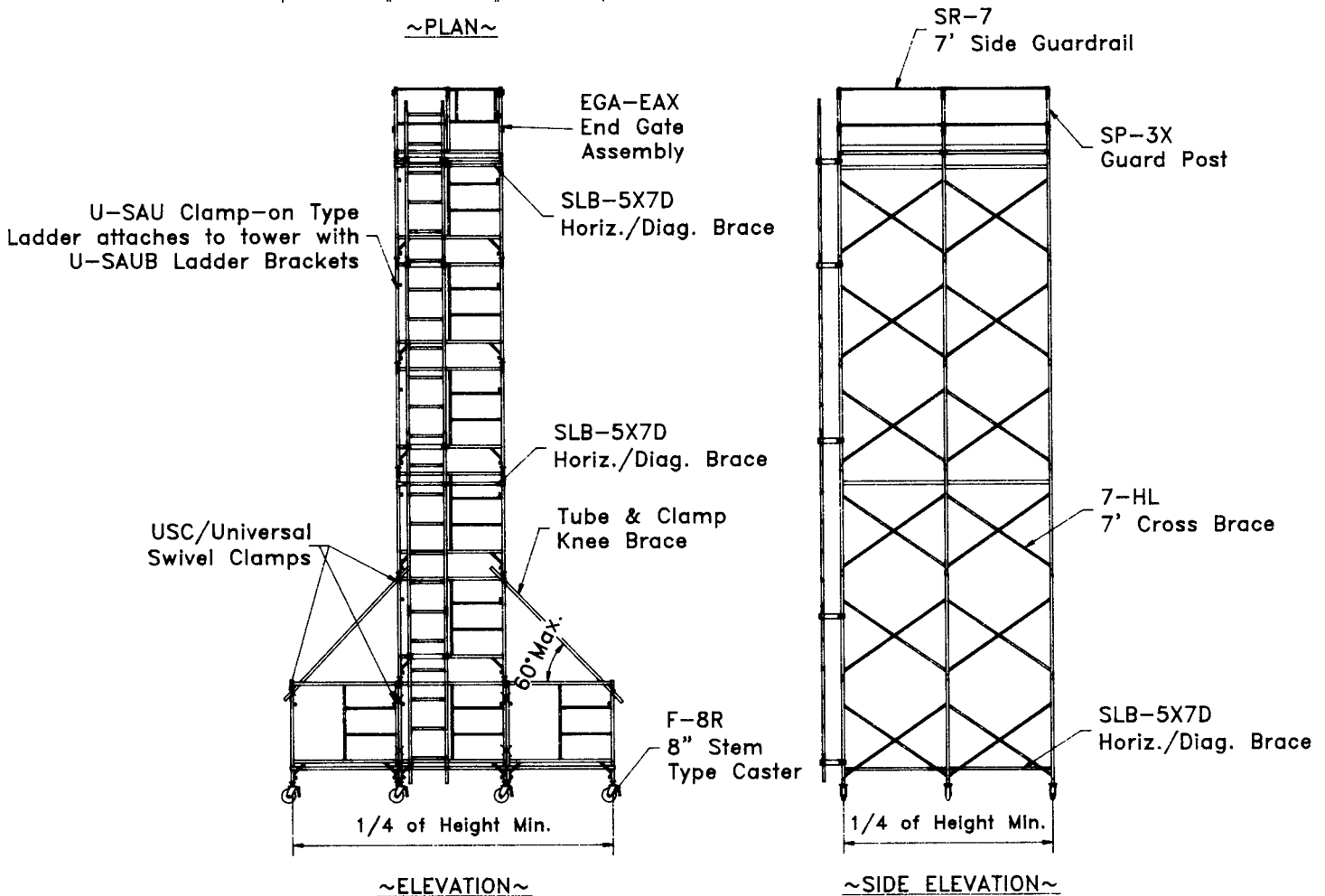

- Notes 1-5 of Typical Rolling Tower page, apply to all rolling units.
- The normal 4:1 height / base ratio must be maintained (some states permit a ratio of only 3:1). To achieve this requirement, it is necessary to extend the base dimensions. The Outriggers can be Standard Scaffold Panels 5' to 6 1/2' high and in widths 3' to 5' or AO-26 Outriggers, which clamp to sides of tower bases.
- The base dimension of the braced Panels is increased by using longer Braces or by the addition of more bays.
- For high rolling scaffold or unusual tower requirements over 30', consult Universal Manufacturing Corp.

PUTLOGS PROPER INSTALLATION

14' - 22' PUTLOGS

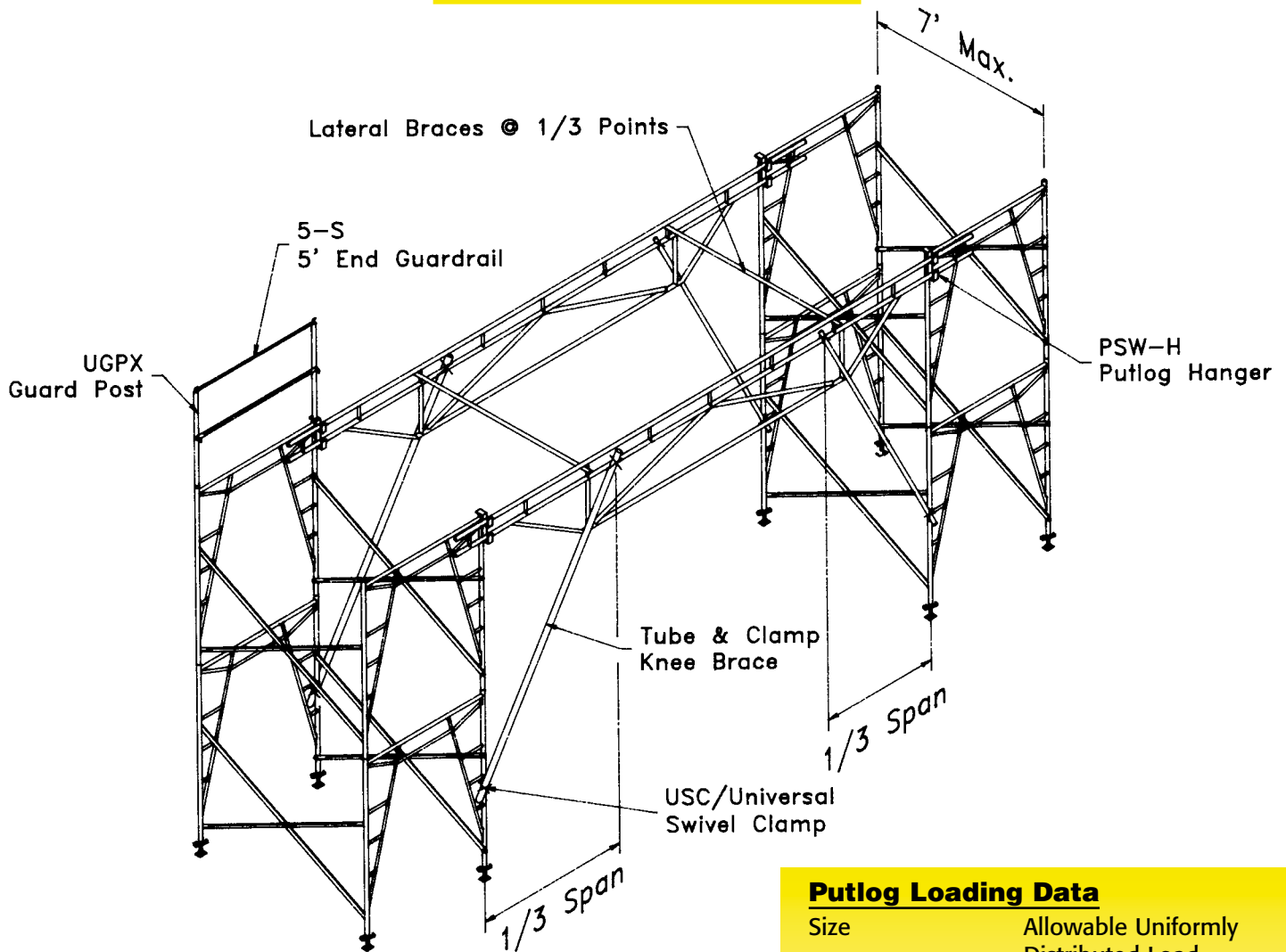

PSW-22
22' Long, 116 lbs. For spans up to 21 feet

PSW-15
15' Long, 69 lbs. For spans up to 14 feet

PSW-12
12' Long, 38 lbs. For spans up to 11 feet

Putlog Loading Data

Size	Allowable Uniformly Distributed Load
PSW-22 MAX. Span 21'	135 lbs./Lineal Foot if Putlogs or 25 lbs./Sq. Ft. when erected in sets of two, as illustrated
PSW-14, 15, 17 MAX. Spans 13', 14', 16'	175 lbs./Lineal Foot of Putlog or 25 lbs./Sq. Ft. when erected in sets of two, as illustrated
PSW-12 MAX. Spans 11'	175 lbs./Lineal Foot of Putlog or 25 lbs./Sq. Ft. when erected in sets of two as illustrated

All loading indicated includes the weight of decking, personnel and material. At no time shall any of these combined loads exceed the allowable shown in data chart.

PUTLOGS PROPER INSTALLATION

12' PUTLOGS

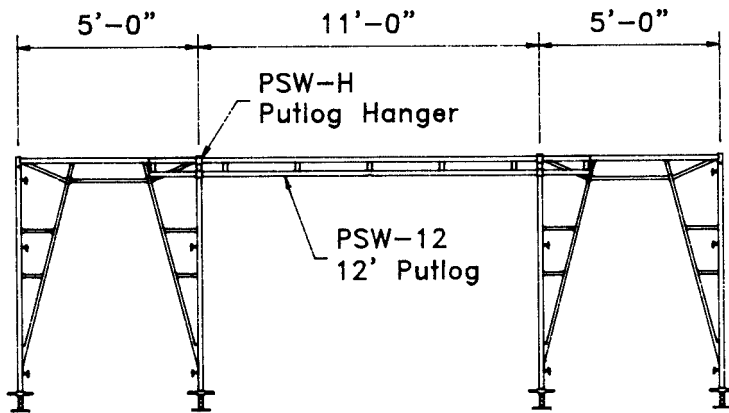

NOTE: All Putlogs may be assembled at intermediate elevations. Attach with at least (2) URC Rigid Clamps at each location.

Putlog Accessories

PSW-H Putlog Hanger

Rigidly supports Putlogs and swivels to allow Putlogs to run in either direction. Attaches without bolts or tools. Hooks over Coupling Pins and rests on Panel Girt. Two required per Putlog. (Weight - 4 lbs.)

PPS-80 Panel Support

Locks over Putlogs or PSW-G Girts to erect Panels above spans. (Weight - 2 lbs.)

PPS-120 Offset Panel Support

Locks over Putlogs and provides support for panels positioned in exact alignment with Tower Panels. (Weight - 5 lbs.)

PSW-G Tie Girt

Provides support between PSW Putlogs in the same direction as Panels. Also used to support two PPS-80 Panel Supports to erect Panels above Putlogs. (Weight - 18 1/2 lbs.)

NOTE: 1) Putlogs and their support panels must never be spaced more than 7 feet apart.

- 2) Knee braces must be used on all Putlogs 14 feet and over. They should attach to Putlogs @ their 1/3 span position. These members may be 1 5/8" diameter tubes if under 10 feet in length. If over 10 feet, use 2 inch tubes. The optimum angle between the knee brace and panel column should be 45° +- 10°.

CAUTION:

When any Putlogs are to be used in conjunction with a rolling tower or similar apparatus, you must consult UNIVERSAL MANUFACTURING CORP. for special instructions and data.

SCAFFOLD ACCESS UNIT

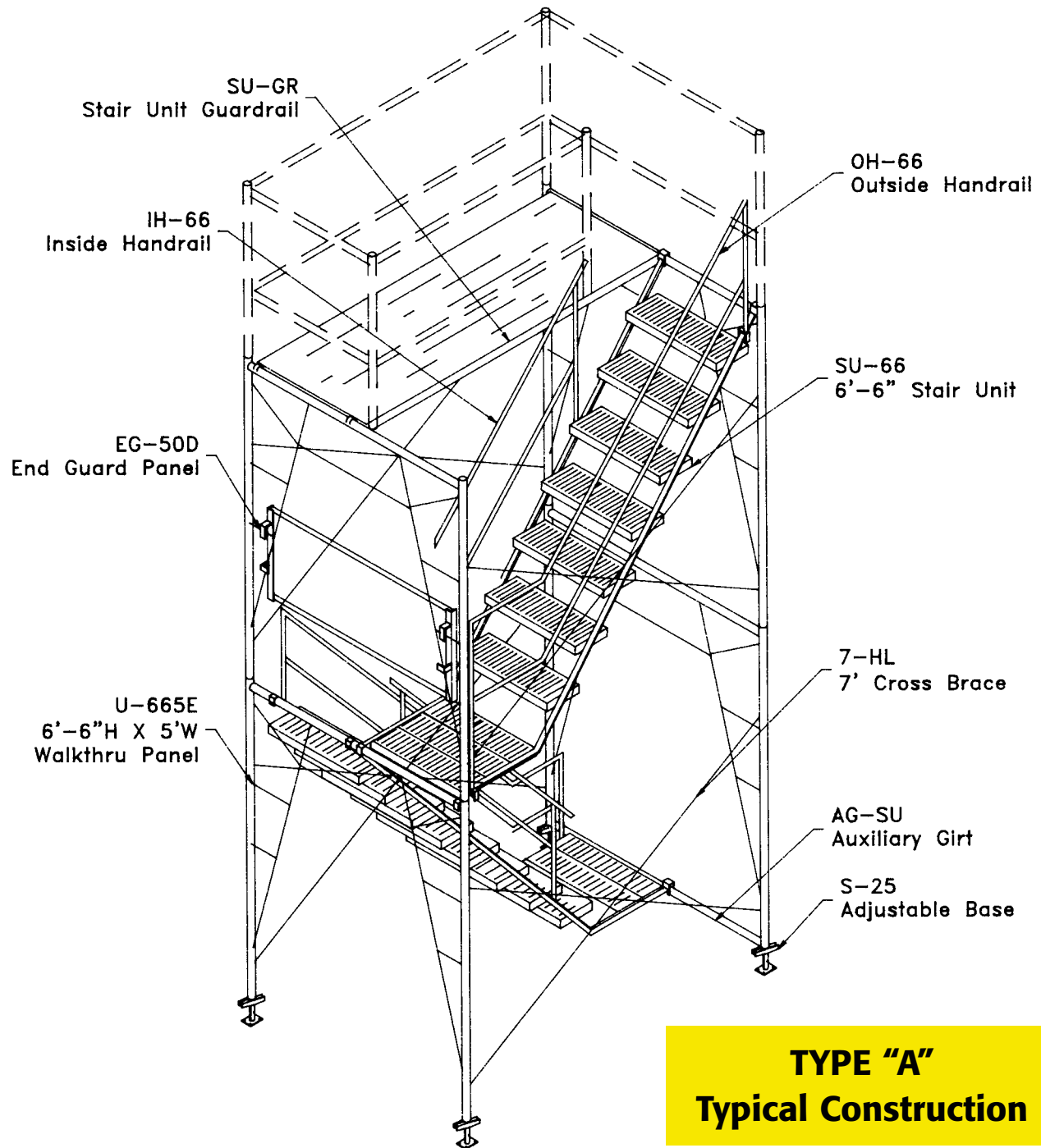

NOTE:

1. Universal's step units are designed to permit three (3) modes of assembly.
TYPE "A" - Staggered steps position allows counterclockwise "ascending."
TYPE "B" - Parallel assembly
TYPE "C" - Allows clockwise "ascending."
2. All Stair Units must be assembled with Handrail as shown.
3. Maximum allowable tower height is 125 feet. If greater heights are required, consult UNIVERSAL MANUFACTURING CORP.
4. The top levels must be protected with Guardrail, Toeboard and Gate Assemblies if necessary.
5. The tower must be guyed or tied to a rigid structure for stability.
6. Capacity - maximum of one man for each 6'-6" level.

SCAFFOLD ACCESS UNIT ALTERNATE CONSTRUCTION

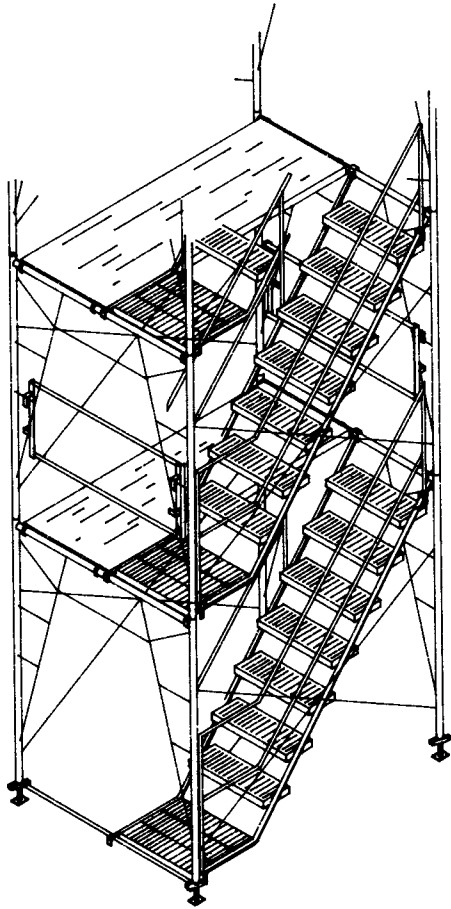

TYPE "B"

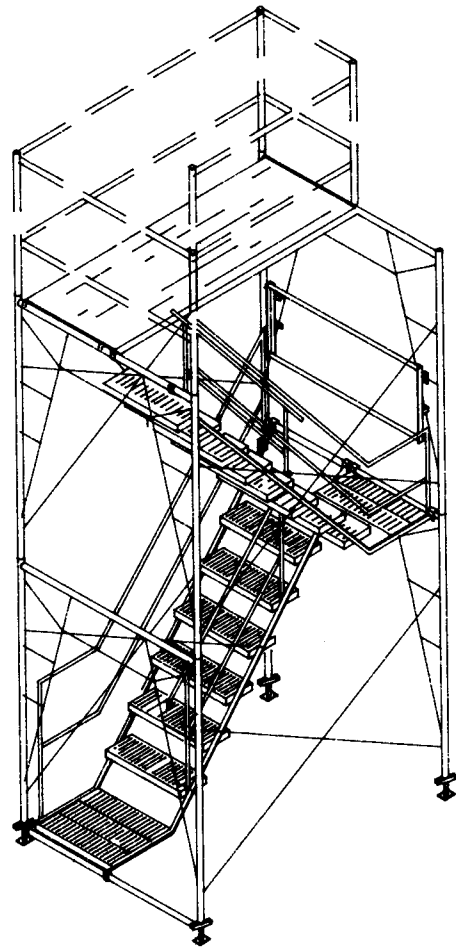

TYPE "C"

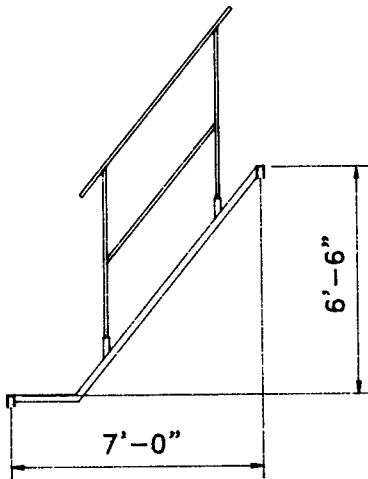

IH-66 INSIDE
Handrail bolts into tubes on side rail.

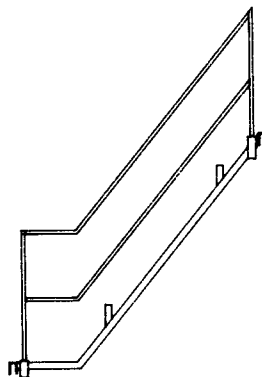

OH-66 OUTSIDE
Handrail clips to side rail. Bolts secure to position required.

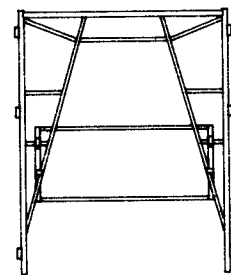

EG-50D
End Guardrail Panel.

TYPICAL TANK LAYOUT

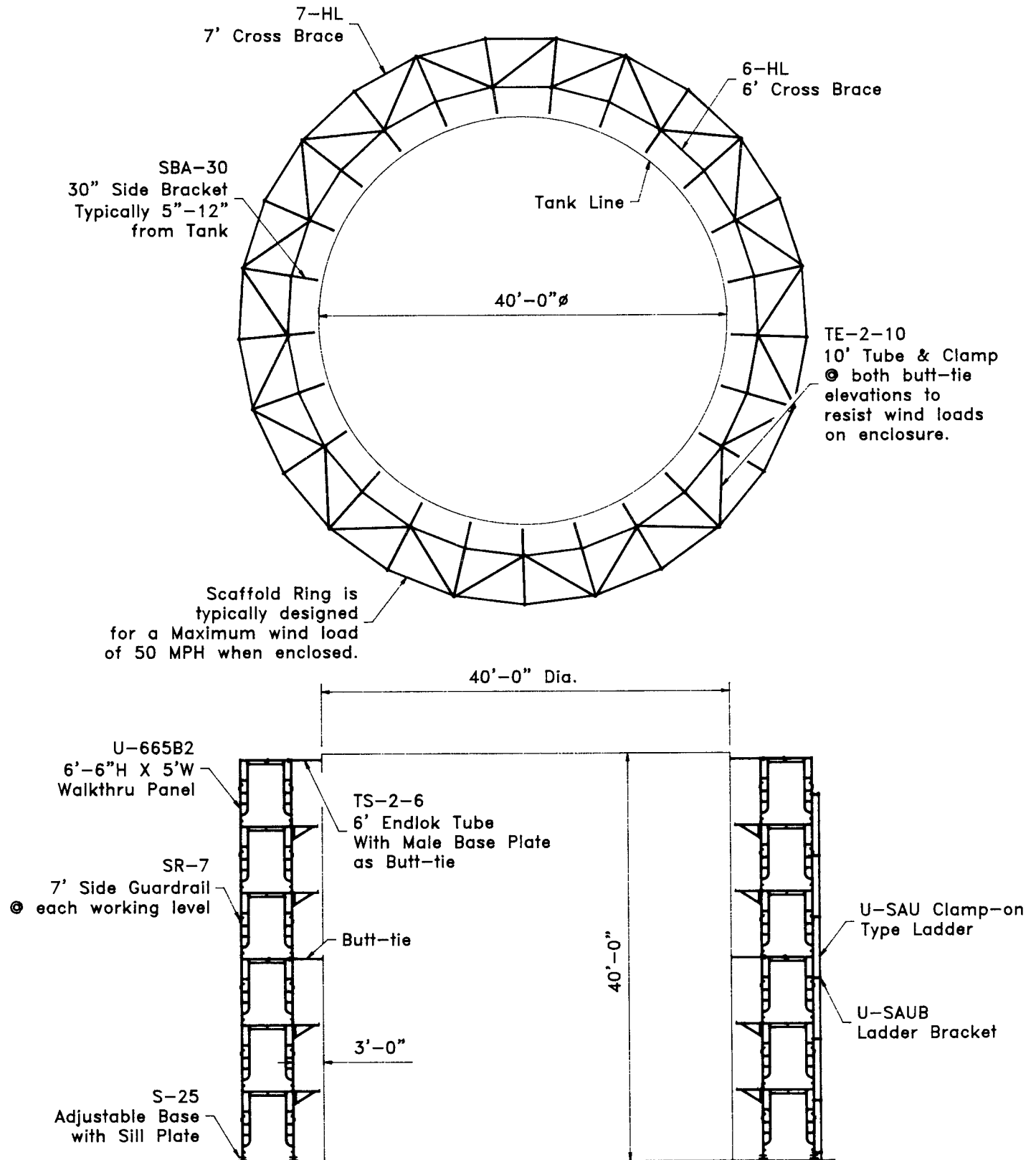

Typical Tank Layout

NOTE:

Other tank size layouts may be designed and engineered by UNIVERSAL MANUFACTURING CORP.

UNIVERSAL SCAFFOLD

The scaffold erection, safety instruction and illustration outlined within this manual apply totally to both of UNIVERSAL'S standard types of Scaffold. All of the associated equipment and accessories can be used with either EZEBILT or UNIBILT Scaffold. The major difference between this equipment is the type of side braces and locking systems.

Details as follows:

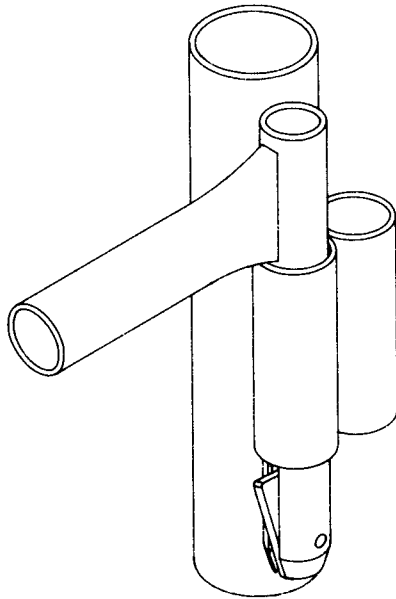

– EZEBILT –

The Side Braces hold the Panels upright and determine the span "X" between Panels. The most popular span is 7 feet; however, spans can vary from 5 feet to 10 feet. The "gravity-lock" on the end of the Brace inserts into the sleeve on the panel leg and locks automatically. "SS" Side Braces are used for Panels 4 1/2 feet in height and greater. "SL" Side Braces are used for Panels 4 feet in height and less. ("SL" braces are identified by a red stripe at the end of the Brace).

For Panels 4 1/2' And Higher	Length Of Brace	Span "X"	For Panels Up To 4' In Height	Length Of Brace	Span "X"
SS-5X	5'-11 3/8"	5'	SL-2 1/2x5	5'-0 5/8"	5'
SS-6X	6'-9 9/16"	6'	SL-2 1/2x6	6'-0 1/8"	6'
SS-7X	7'-8 3/32"	7'	SL-2 1/2x7	7'-0 1/16"	7'
SS-8X	8'-6 7/8"	8'	SL-2 1/2x8	7'-11 23/32"	8'
SS-9X	9'-6 1/16"	9'	SL-2 1/2x9	8'-11 3/4"	9'
SS-10X	10'-5 1/4"	10'	SL-2 1/2x10	9'-11 1/4"	10'

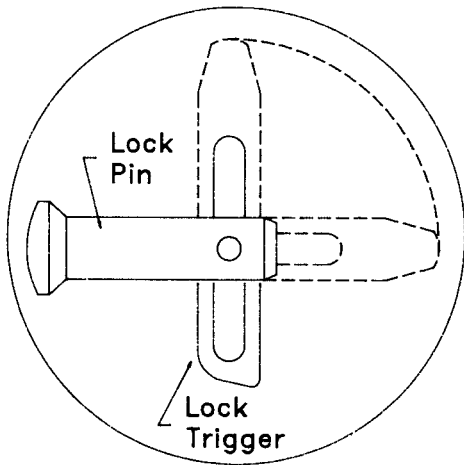

Braces for UNIBILT are fastened securely to the Panel by the use of UNIBILT'S exclusive "BRACE LOCK" which allows fast, easy assembly of scaffold units.

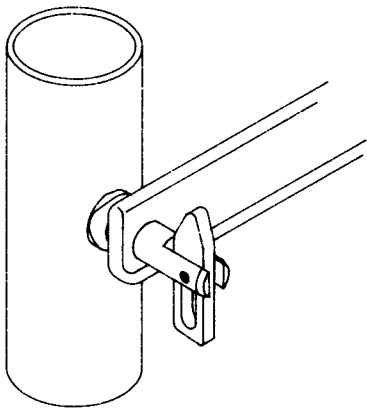

With lock bar in the horizontal position, the Braces slip easily on the "BRACE LOCK", and with finger pressure, the lock bar moves into the vertical position which locks the Braces to the Panel until released manually.

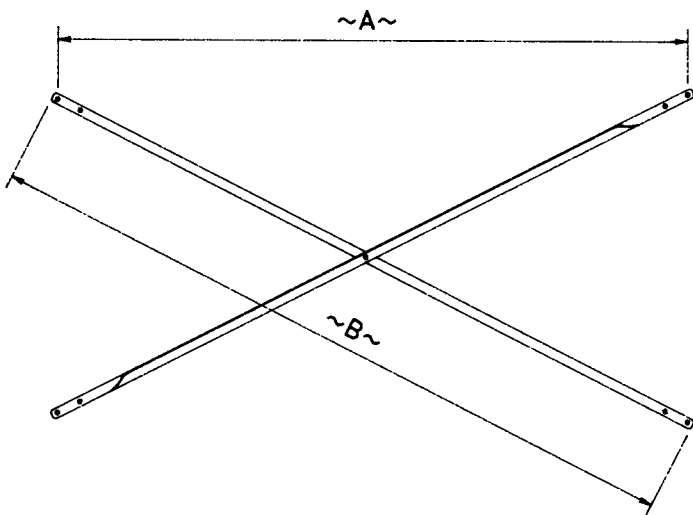

The Cross Braces for UNIBILT are structural steel angles. The Braces have 9/16" diameter holes in the ends to slip over the brace locks on the Panels and are riveted together at the center with 3/8" rivets to form a complete "X". The "HL" - type Cross Brace is used with 305, 405, 465, 505 and 665 Panels and are available in the following sizes:

NOTE:

These Angle-Type Braces are also available in pre-galvanized tubular steel up to the 8-HL size.

Cat. No.	"A"	"B"	Weight
4-HL	4'-0"	5'-5"	11.3
5-HL	5'-0"	6'-3"	13.1
6-HL	6'-0"	7'-1"	14.6
7-HL	7'-0"	7'-11"	16.4
8-HL	8'-0"	8'-10"	18.3
9-HL	9'-0"	9'-9"	20.1
10-HL	10'-0"	10'-9"	22.0

SCAFFOLD INSPECTION PROCEDURES

Universal Manufacturing Corp. recommends the following inspection procedure as a general guideline for the assessment of constructed scaffolds. This procedure is not to be used as a substitute for training, experience and knowledge. All scaffolds, by law must be constructed under the supervision of a competent person, a person who can identify hazards and has the authority to eliminate the hazards.

- Familiarize yourself with all applicable codes, standards and regulations, including company rules.
- Inspect the overall jobsite for organization, housekeeping, coordination of workers, safety equipment and safety procedures.
- Observe the erection crew for procedure, fall protection, coordination and organization.
- Observe the overall scaffold. Does it appear to be constructed properly?
- Is the scaffold plumb?
- Is the scaffold level?
- Are Guardrail Systems installed on all open platforms?
- Is the top guardrail between 38-45 inches from the work surface?
- If there is no Guardrail System, are occupants wearing proper fall arrest equipment?
- Is falling object protection provided where required?
- Is the scaffold tied to the structure, and is the spacing per this manual's requirements?
- Inspect the foundation. Are there sills?
- If Screw Jacks are used, are the handles tight?
- Are there Base Plates?
- Is there full contact between the Base Plates and the sills and/or foundations?
- Is there any evidence of settlement?
- Is there any evidence of wet soil or erosion?
- Is there access?
- How high is the first step? (It should be less than 24 inches)
- If a ladder is used, is there a rest platform at 35 feet or less?
- Does the ladder extend above the top platform or is there a handhold?
- Is there proper access between the ladder and the platform?
- If a stairway is used, are the handrails and guardrails installed?
- How do the platforms look?
- Are all platforms at least 18 inches wide?
- Is the space between the platform and the work surface less than 14 inches?
- What is the maximum spacing between plank? (It should be less 1 inch)
- Is there proper support for the plank?
- Are cantilevers minimized and within the regulations?
- If side brackets or outriggers are used, are they properly installed?
- Are all scaffold components in good condition?
- Are the materials loaded on the scaffold safely supported?

GIVE TO SCAFFOLD ERECTOR & USER OR POST ON JOB

CODE OF SAFE PRACTICES FOR

FRAME SCAFFOLDS, SYSTEM SCAFFOLDS, TUBE AND CLAMP SCAFFOLDS & ROLLING SCAFFOLDS

DEVELOPED FOR INDUSTRY BY
SCAFFOLD INDUSTRY ASSOCIATION, INC.

It shall be the responsibility of all users to read and comply with the following common sense guidelines which are designed to promote safety in the erecting, dismantling and use of Scaffolds. These guidelines do not purport to be all-inclusive nor to supplant or replace other additional safety and precautionary measures to cover usual or unusual conditions. If these guidelines in any way conflict with any state, local, federal or other government statute or regulation, said statute or regulation shall supersede these guidelines and it shall be the responsibility of each user to comply therewith.

I. GENERAL GUIDELINES

- A. **POST THESE SCAFFOLDING SAFETY GUIDELINES** in a conspicuous place and be sure that all persons who erect, dismantle or use scaffolding are aware of them.
- B. **FOLLOW ALL STATE, LOCAL AND FEDERAL CODES, ORDINANCES AND REGULATIONS** pertaining to scaffolding.
- C. **SURVEY THE JOB SITE.** A survey shall be made of the job site for hazards, such as untamped earth fills, ditches, debris, high tension wires, unguarded openings, and other hazardous conditions created by other trades. These conditions should be corrected or avoided as noted in the following sections.
- D. **INSPECT ALL EQUIPMENT BEFORE USING.** Never use any equipment that is damaged or defective in any way. Remove it from the job site.
- E. **SCAFFOLDS MUST BE ERECTED IN ACCORDANCE WITH DESIGN AND/OR MANUFACTURERS' RECOMMENDATIONS.**
- F. **DO NOT ERECT, DISMANTLE OR ALTER A SCAFFOLD** unless under the supervision of a qualified person.
- G. **DO NOT ABUSE OR MISUSE THE SCAFFOLD EQUIPMENT.**
- H. **ERECTED SCAFFOLDS SHOULD BE CONTINUALLY INSPECTED** by users to be sure that they are maintained in safe condition. Report any unsafe condition to your supervisor.
- I. **NEVER TAKE CHANCES! IF IN DOUBT REGARDING THE SAFETY OR USE OF THE SCAFFOLD, CONSULT YOUR SCAFFOLD SUPPLIER.**
- J. **NEVER USE EQUIPMENT FOR PURPOSES OR IN WAYS FOR WHICH IT WAS NOT INTENDED.**
- K. **DO NOT WORK ON SCAFFOLDS** if your physical condition is such that you feel dizzy or unsteady in any way.

II. GUIDELINES FOR ERECTION AND USE OF SCAFFOLDS

- A. **SCAFFOLD BASE MUST BE SET ON AN ADEQUATE SILL OR PAD** to prevent slipping or sinking and fixed thereto where required. Any part of a building or structure used to support the scaffold shall be capable of supporting the maximum intended load to be applied.
- B. **USE ADJUSTING SCREWS** or other approved methods instead of blocking to adjust to uneven grade conditions.
- C. **BRACING, LEVELING & PLUMBING OF FRAME SCAFFOLDS —**
 - 1. Plumb and level all scaffolds as the erection proceeds. Do not force frames or braces to fit — level the scaffold until proper fit can easily be made.
 - 2. Each frame or panel shall be braced by horizontal bracing, cross bracing, diagonal bracing or any combination thereof for securing vertical members together laterally. All brace connections shall be made secure, in accordance with the manufacturer's recommendations.
- D. **BRACING, LEVELING & PLUMBING OF TUBE & CLAMP AND SYSTEM SCAFFOLDS —**
 - 1. **POSTS SHALL BE ERECTED PLUMB** in all directions, with the first level of runners and bearers positioned as close to the base as feasible. The distance between bearers and runners shall not exceed manufacturer's recommended procedures.
 - 2. **PLUMB, LEVEL AND TIE** all scaffolds as erection proceeds.
 - 3. **FASTEN ALL COUPLERS AND/OR CONNECTIONS** securely before assembly of next level.
 - 4. **VERTICAL AND/OR HORIZONTAL DIAGONAL BRACING MUST BE INSTALLED** according to manufacturer's recommendations.
- E. **TIE CONTINUOUS (RUNNING) SCAFFOLDS TO THE WALL OR STRUCTURE** at each end and at least every 30 feet of length when scaffold height exceeds the maximum allowable free standing dimension.
Begin ties or stabilizers when the scaffold height exceeds that dimension, and repeat at vertical intervals not greater than 26 feet. The top anchor shall be placed no lower than four (4) times the base dimension from the top of the completed scaffold. Anchors must prevent scaffold from tipping into or away from wall or structure. Stabilize circular or irregular scaffolds in such a manner that completed scaffold is secure and restrained from tipping.
When scaffolds are partially or fully enclosed or subjected to overturning loads, specific precautions shall be taken to insure the frequency and accuracy of ties to the wall and structure. Due to increased loads resulting from wind or overturning loads the scaffolding component to which ties are subjected shall be checked for additional loads.
- F. **WHEN FREE STANDING SCAFFOLD TOWERS** exceed four (4) times their minimum base dimension vertically, they must be restrained from tipping. (CAL/OSHA and some government agencies require stricter ratio of 3 to 1.)
- G. **DO NOT ERECT SCAFFOLDS NEAR ELECTRICAL POWER LINES UNLESS PROPER PRECAUTIONS ARE TAKEN.** Consult the power service company for advice.
- H. **A MEANS OF ACCESS TO ALL PLATFORMS SHALL BE PROVIDED.**
- I. **DO NOT USE ladders or makeshift devices on top of scaffolds to increase the height.**
- J. **PROVIDE GUARDRAILS AND MID-RAILS AT EACH WORKING PLATFORM LEVEL** where open sides and ends exist, and toeboards where required by code.

K. BRACKETS AND CANTILEVERED PLATFORMS —

1. Brackets for **SYSTEM SCAFFOLDS** shall be installed and used in accordance with manufacturer's recommendations.
2. Brackets for **FRAME SCAFFOLDS** shall be seated correctly with side bracket parallel to the frames and end brackets at 90 degrees to the frames. Brackets shall not be bent or twisted from normal position. Brackets (except mobile brackets designed to carry materials) are to be used as work platforms only and shall not be used for storage of material or equipment.
3. Cantilevered platforms shall be designed, installed and used in accordance with manufacturer's recommendations.

L. ALL SCAFFOLDING COMPONENTS shall be installed and used in accordance with the manufacturers' recommended procedure. Components shall not be altered in the field.

Scaffold frames and their components manufactured by different companies shall not be intermixed, unless the component parts readily fit together and the resulting scaffold's structural integrity is maintained by the user.

M. PLANKING —

1. Working platforms shall cover scaffold bearer as completely as possible. Only scaffold grade wood planking, or fabricated planking and decking meeting scaffold use requirements shall be used.
2. Check each plank prior to use to be sure plank is not warped, damaged, or otherwise unsafe.
3. Planking shall have at least 12" overlap and extend 6" beyond center of support, or be cleated or restrained at both ends to prevent sliding off supports.
4. Solid sawn lumber, LVL (laminated veneer lumber) or fabricated scaffold planks and platforms (unless cleated or restrained) shall extend over their end supports not less than 6" nor more than 18". This overhang should not be used as a work platform.

N. FOR "PUTLOGS" AND "TRUSSES" THE FOLLOWING ADDITIONAL GUIDELINES APPLY:

1. Do not cantilever or extend putlogs/trusses as side brackets without thorough consideration for loads to be applied.
2. Putlogs/trusses should be extended at least 6" beyond point of support.
3. Place recommended bracing between putlogs/trusses when the span of putlog/truss is more than 12 feet.

O. FOR ROLLING SCAFFOLDS THE FOLLOWING ADDITIONAL GUIDELINES APPLY:

1. **RIDING A ROLLING SCAFFOLD IS VERY HAZARDOUS.** The Scaffold Industry Association does not recommend nor encourage this practice. However, if you choose to do so, be sure to follow all state, federal or other governmental guidelines.
2. Casters with plain stems shall be attached to the panel or adjustment screw by pins or other suitable means.
3. No more than 12 inches of the screw jack shall extend between the bottom of the adjusting nut and the top of the caster.
4. Wheels or casters shall be provided with a locking means to prevent caster rotation and scaffold movement and kept locked.
5. Joints shall be restrained from separation.
6. Use horizontal diagonal bracing near the bottom and at 20 foot intervals measured from the rolling surface.
7. Do not use brackets or other platform extensions without compensating for the overturning effect.
8. The platform height of a Rolling Scaffold must not exceed four (4) times the smallest base dimension (CAL/OSHA and some Government agencies require a stricter ratio of 3 to 1).
9. Cleat or secure all plank.
10. Secure or remove all materials and equipment from platform before moving.
11. Do not attempt to move a rolling scaffold without sufficient help — watch out for holes in floor and overhead obstructions — stabilize against tipping.

P. SAFE USE OF SCAFFOLD —

1. Prior to use, inspect scaffold to insure it has not been altered and is in safe working condition.
2. Erected scaffolds and platforms should be inspected continuously by those using them.
3. Exercise caution when entering or leaving a work platform.
4. Do not overload scaffold. Follow manufacturer's safe working load recommendations.
5. Do not jump onto planks or platforms.
6. Do not use ladders or makeshift devices on top of working platforms to increase the height or provide access from above.
7. Climb in access areas only and **USE BOTH HANDS.**

III. WHEN DISMANTLING SCAFFOLDING THE FOLLOWING ADDITIONAL GUIDELINES APPLY:

- ✓ **A.** Check to assure scaffolding has not been structurally altered in a way which would make it unsafe and, if it has, reconstruct where necessary before commencing with dismantling procedures. This includes all scaffold ties.
- B.** Visually inspect plank prior to dismantling to be sure they are safe.
- C.** Consideration must be given as to the effect removal of a component will have on the rest of the scaffold prior to that component's removal.
- D.** Do not accumulate excess components or equipment on the level being dismantled.
- E.** Do not remove ties until scaffold above has been removed (dismantled).
- F.** Lower dismantled components in an orderly manner. Do not throw off of scaffold.
- G.** Dismantled equipment should be stockpiled in an orderly manner.
- H. FOLLOW ERECTION PROCEDURES AND USE MANUALS.**

These safety guidelines (Codes of Safe Practice) set forth common sense procedures for safely erecting, dismantling and using scaffolding equipment. However, equipment and scaffolding systems differ, and accordingly, reference must always be made to the instructions and procedures of the supplier and/or manufacturer of the equipment.

Since field conditions vary and are beyond the control of the Scaffold Industry Association, safe and proper use of scaffolding is the sole responsibility of the user.